

Stool Collection Instructions

Please read all of this material *before* you start your stool collection.

Collect a stool sample for testing

Your health care provider wants you to collect a sample of your stool. The stool sample will be tested to determine whether you are passing blood that cannot be seen. If you have questions, contact your health care provider.

Your stool collection is for:

- 24 hours
- 48 hours
- 72 hours

Your stool test will not be accurate and you may need to do the stool collection again if, for any reason, any of the stool you pass during the checked time period is not put into the provided collection containers and returned as instructed.

Stool collection kit

Your stool collection kit contains:

- This patient instruction material.
- Two screw-capped stool collection containers.
 - Use only the collection containers provided. This helps with correct handling and reporting of test results to your health care provider.
- A plastic holder to hold the collection container in the toilet.

Before you start

For **72 hours** before you start collecting stool and during the time you collect stool:

- Do not use laxatives, including mineral oil and castor oil.
- Do not eat synthetic fat substitutes, such as Olestra™.
- Do not take fat-blocking nutritional supplements.

If your stool will be tested for fat, follow any special instructions for your diet given by your physician. Start the diet **at least 72 hours** before you start collecting stool.

If you have a barium enema, **wait until 48 hours after** the enema before you start collecting stool. Barium interferes with stool testing.

Start your stool collection:

- On this date _____
- As soon as you can

Collecting stool instructions

If you have questions about these collection instructions, contact your physician's office.

1. Lift the toilet seat. Place the plastic holder across the rim of the toilet bowl so the shorter supports are at the back of the toilet bowl and the longer supports are in the middle of the toilet bowl.
2. Remove the cap from the collection container.
3. Place the container in the hole of the holder (Figure 1).

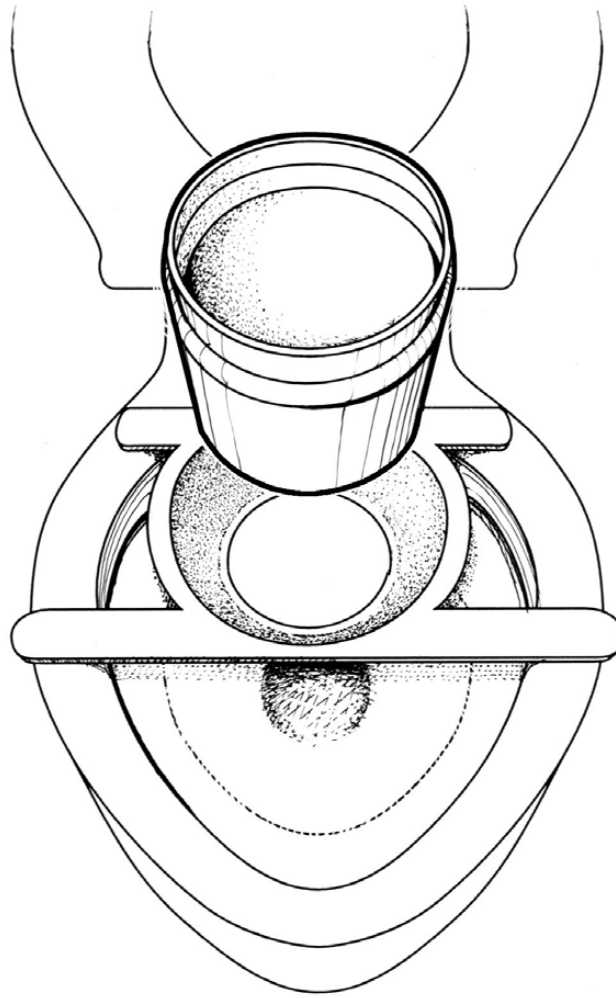

Figure 1. Placing the collection container in holder

- Put the toilet seat down (Figure 2). Depending on the water level in the toilet and the shape of the toilet seat, the collection container may float and rise.

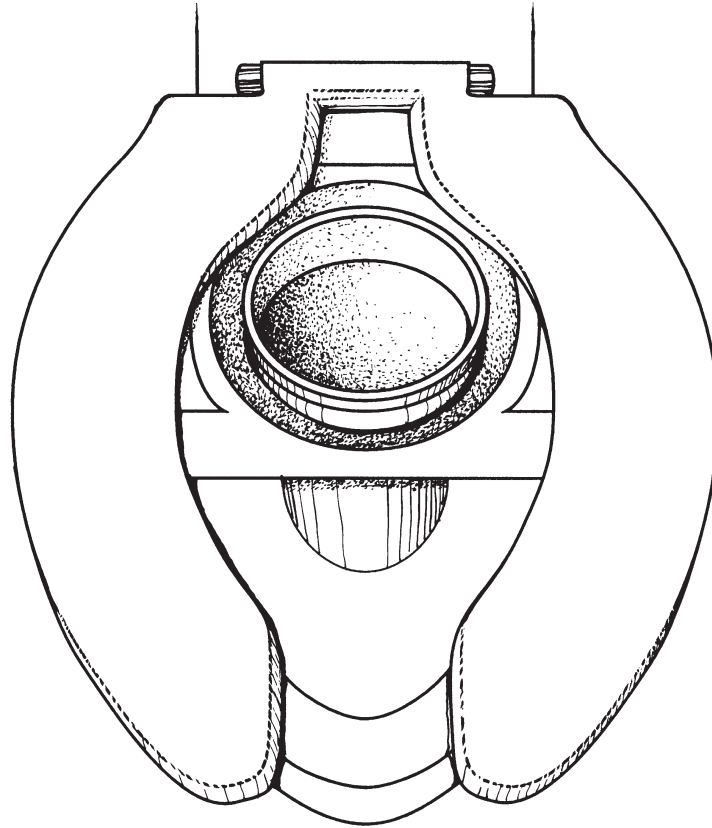

Figure 2. Collection container in holder with toilet seat down

- After your bowel movement, remove the collection container. With the container on a flat surface, place the lid on top of the container and press down firmly until you hear a “click” or “snap.” Then screw the lid on the rest of the way; it may not screw very far.

Add stool to either of the two collection containers if you have more than two bowel movements during the specified time period.

If you prefer, keep the closed collection container in the refrigerator to lessen the odor. This will not affect your test results.

When your collection is complete, make sure you have screwed the cap evenly and tightly onto the collection container. Discard the toilet adapter. Label containers X of X (ie, 1 of 2, 2 of 2). Return the entire collection to your physician’s office.

This material is for your education and information only. This content does not replace medical advice, diagnosis or treatment. New medical research may change this information. If you have questions about a medical condition, always talk with your health care provider.